

**santamargherita**  
THE ORIGINAL ITALIAN SURFACE

SM QUARTZ FABRICATION MANUAL

# TABLE OF CONTENTS

· <b>Product description</b>	4
· <b>Safety</b>	6
· Worker safety	6
· Risk information label	7
· <b>Handling and storage</b>	8
· Transport	8
· Handling	8
· Storage	9
· Size and weight	10
· Label	11
· <b>Slab inspection</b>	12
· Initial inspection	12
· <b>Fabrication equipment</b>	14
· Personal protective equipment	14
· Fabrication tools	14
· <b>Fabrication tips</b>	16
· Cutting the slab	16
· General instructions for cutting	18
· Tips to avoid breakage	19
· General instructions for cutting with CNC	24
· General instructions for cutting with Waterjet	25
· Polishing edges	26
· Positioning joints and gluing	27
· <b>Counter installation</b>	31
· Installation instructions	31
· Overhangs	32
· Post installation troubleshooting	33

· <b>Care and maintenance</b>	34
·     Cleaning after fabrication	34
·     Cleaning after installation	34
·     Cleaning and routine maintenance	35
·     Cleaning stubborn stains	35
·     Preventing damage from thermal shock and impact	35
·     Recommended products for cleaning	36
· <b>Technical features</b>	38
·     Technical specifications	38
·     Stain resistance	39

## PRODUCT DESCRIPTION

A leading company in engineered marble and quartz surfaces, Santa Margherita has been synonymous with research, innovation and Italian culture. Located in the foothills of the Verona area in Italy, on a site of over 1100000 sq.ft., Santa Margherita manufactures over 75000 sq.ft. of engineered stones daily, which is distributed to more than 70 countries.

Elegant and resistant, SANTAMARGHERITA® quartz agglomerate is the ideal solution for outstanding performance surfaces.

Crafted from carefully selected quartz and certified resin for contact with food and a healthy environment, it is ideal for a wide variety of applications in large spaces such as most sought after interior design solutions.

Resistant to flexion, abrasion and acids, SM Quartz® products offer a large choice of colors, textures and innovative finishes, which can be customized with waterjet cutting and sublimation printing.

4



5



“SANTAMARGHERITA - The Original Italian Surface® is created from the most advanced technology combining aesthetics and superior performances”

santamargherita

# SAFETY

## WORKER SAFETY

Worker safety is fundamental for Santa Margherita SpA, therefore, before you start fabricating SM QUARTZ please refer to the following documents:

- “Guide to good fabrication practices”.
- “Safety guidelines for fabrication”.

which will provide you with the necessary information to protect yourself from risks associated with the operations that you are about to perform.

# RISK INFORMATION LABEL

Each slab has a safety label on the back with basic information and risks concerning fabrication.



MORE INFO

IT

## AVVISO AL PERSONALE

Uso dei Materiali: Superfici in quarzo progettate per piani cucina e bagno, pavimenti, rivestimenti e altri usi architettonici. Composizione (%): Il materiale è costituito da aggregati minerali inorganici (85-95%), tra cui, ma non solo, sabbia silicea, quarzo, cristobalite, vetro ed altri, poliestere (5-15%), pigmenti e additivi (<5%). Nel Regolamento CLP (CE) n° 1272/2008 non vi è alcuna disposizione per rischi connessi con il materiale finito SM QUARTZ®. Tuttavia, durante la lavorazione e l'installazione del materiale, è necessario considerare le seguenti informazioni. Si prega di leggere con attenzione.

## LAVORAZIONE ED INSTALLAZIONE

Questo materiale deve essere lavorato utilizzando metodi che comportano l'uso di acqua per evitare la formazione di polvere. La polvere derivata dai processi di produzione contiene Silice Cristallina (SiO<sub>2</sub>). L'esposizione a lungo termine senza protezioni alla polvere derivata dai processi di lavorazione, taglio e lucidatura, può causare malattie gravi come la pneumoconiosi, la silicosi nonché il deterioramento polmonare, con malattie come la bronchite, l'emfisema, ecc. I produttori devono rispettare la Normativa Nazionale vigente. Per maggiori informazioni leggere i documenti "Indicazioni di Sicurezza per la Lavorazione" e la "Guida alle Buone Pratiche di Lavorazione". Informazioni disponibili presso [www.santamargherita.net](http://www.santamargherita.net)

EN

## WARNING TO STAFF

Use of the material: Quartz surfacing designed for kitchen and bathroom worktops, flooring, cladding and other architectural uses. Composition (%): The material is made up of inorganic mineral deposits (85-95%), including, but not limited to, silica sand, quartz, cristobalite, glass and others, polyester (5-15%), pigments and additives (<5%). There is no provision for any risk associated with the finished SM QUARTZ® material in the CLP (CE) regulation n°. 1272/2008. However, during manufacturing and installation of the material, it is necessary to consider the following information. Please read carefully.

## FABRICATION AND INSTALLATION

This material should be fabricated using methods that involve the use of water to avoid the creation of dust. Dust derived of manufacturing processes contains Crystalline Silica (SiO<sub>2</sub>). Long term unprotected exposure to dust derived from the cutting, polishing and manufacturing processes may cause serious diseases as pneumoconiosis, silicosis as well the deterioration of lungs including diseases such as bronchitis, emphysema, etc. Fabricators should comply with all applicable governmental regulations. For specific information on each case, please, read our Safety Indication for Working and Good Practice Guide to manufacture. Information available at [www.santamargherita.net](http://www.santamargherita.net)

FRASI DI RISCHIO E SICUREZZA PREVISTE PER LA FRAZIONE RESPIRABILE DI SILICE CRISTALLINA (SiO <sub>2</sub> ).		HEALTH & SAFETY INFORMATION ABOUT CRYSTALLINE SILICA (SiO <sub>2</sub> ) RESPIRABLE FRACTION.
<b>PERICOLI</b> H372: Provoca danni ai polmoni in caso di esposizione prolungata o ripetuta per inalazione.		<b>HAZARD</b> H372: Causes damage to lungs through prolonged or repeated exposure (inhalation)
<b>PREVENZIONE</b> P260: Non respirare la polvere generata nei processi di taglio, levigatura o lucidatura. P264: Lavare accuratamente viso e mani dopo l'uso. P270: Non mangiare, né bere, né fumare durante l'uso. P284: Utilizzare un apparecchio respiratorio per polveri (P3).		<b>PREVENTION</b> P260: Do not breathe dust generated in the cutting, grinding and polishing processes. P264: Wash face and hands thoroughly after handling. P270: Do not eat, drink or smoke when using this material. P284: Wear respiratory protection for particles (P3).
<b>MISURE DI PRIMO SOCCORSO</b> P314: In caso di malessere consultare un medico. P501: Smaltire il prodotto in accordo con le leggi locali.		<b>FIRST AID MEASURES</b> P314: Get medical advice/attention if you feel unwell. P501: Dispose of scrap material in accordance with local regulation

L14

# HANDLING AND STORAGE

## TRANSPORT

The slabs must be loaded in an upright position onto the truck, resting on special metal posts or A frames and securely fastened with chains or straps, placing a wooden board between the chain and the slab to prevent damage to the load.

To avoid scratching the finished surface (gloss finish, polished), slabs should be loaded face to face and back to back. The slabs with special finishes (Wave and Metropolis), should have the rough surface against the finished surface with a plastic film in between.

For container transport the slabs will be supplied in special wooden crates suitably secured within the container.



## HANDLING

The slabs must be handled by using an overhead crane or forklift using pinch clamps or steel cables with plastic coating. We recommend not using uncoated cables as they may damage the slabs during handling.



## STORAGE

The slabs must be kept in a covered warehouse with the finished surface away from direct sunlight so as to avoid any discoloration of the exposed areas.

The metal stands (A-frames) must have at least two support points tilted at about 15° and appropriately spaced (5'-7" / 6'-3") in order to prevent the slabs from warping. For the storage of slabs that are less than 3/4" thick it is recommended to rest the slabs on a solid surface, for example by putting a 1-1/4" slab as a backer slab.

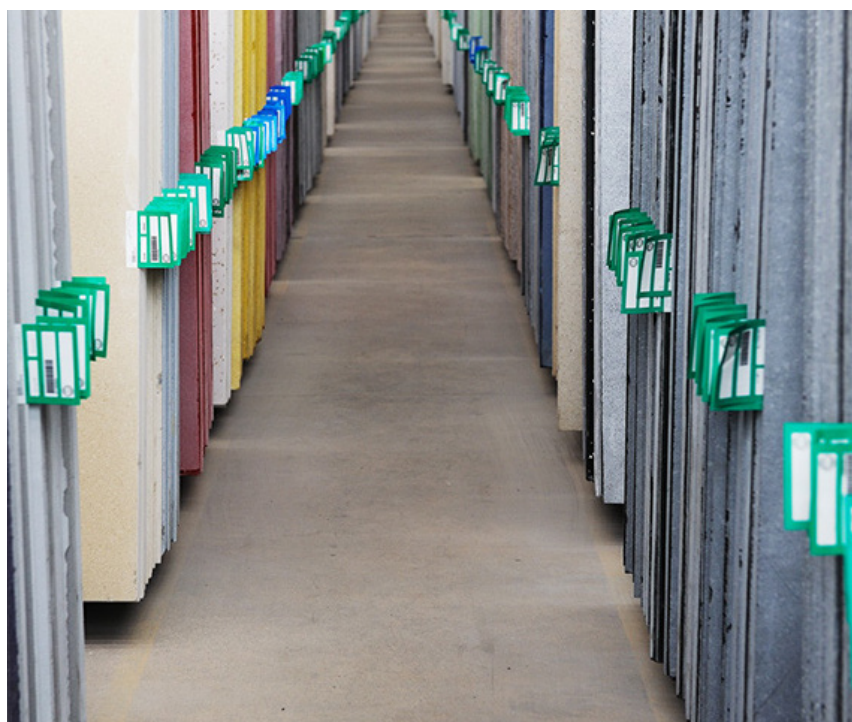

# HANDLING AND STORAGE

## SIZE AND WEIGHT

SM Quartz is available in sizes:

FORMAT	SIZE	WEIGHT PER UNIT
Standard	120" x 55" x 1/2"	287 lbs
	120" x 55" x 3/4"	463 lbs
	120" x 55" x 1-1/4"	683 lbs
Grande	126" x 61" x 3/4"	529 lbs
	126" x 61" x 1-1/4"	794 lbs

10

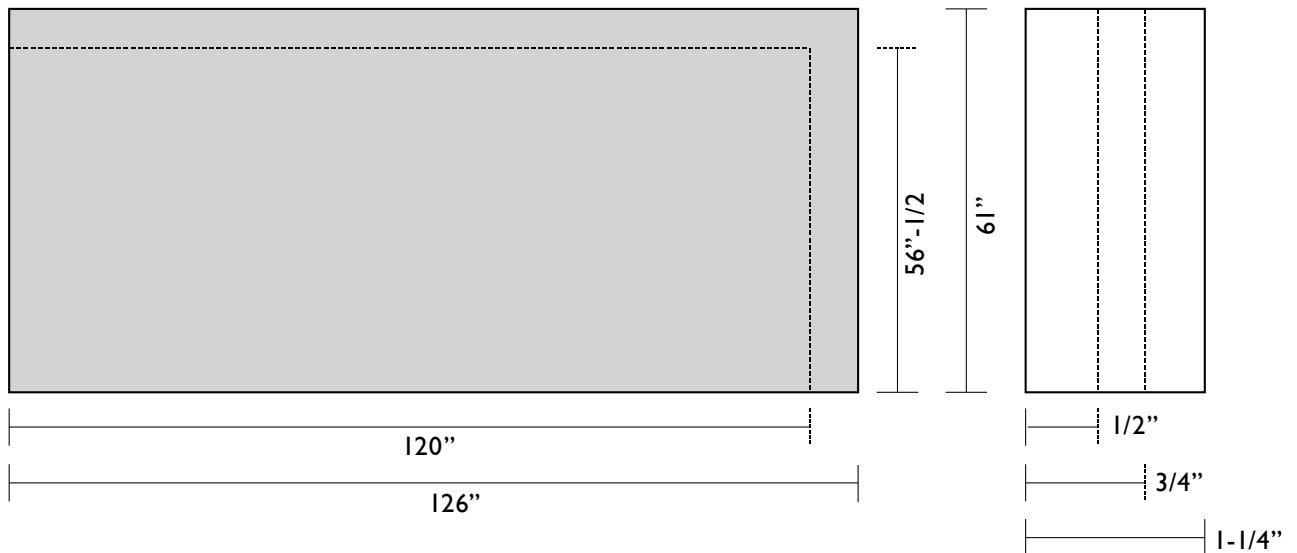

NOTE: Not all colors are available in every size and thickness.

# LABEL



MATERIALE / MATERIAL	LOTTO / LOT
BARCODE	

Green label, for first choice products.



MATERIALE / MATERIAL	LOTTO / LOT
BARCODE	

Yellow label, for second choice products.

# SLAB INSPECTION

## INITIAL INSPECTION

The slabs supplied by Santa Margherita S.p.A. are all subjected to a careful visual inspection to rule out the presence of defects. Prior to fabrication, a careful inspection of the slabs is required.

Carefully check the slab surface which, depending on the finishing process, must have a smooth appearance and meet the following criteria:

- No presence of foreign materials.
- No residue of color or mixture of the material produced previously bigger than 3/16".
- No holes or scratches.
- No pigment stains larger than 3/16" (only for monochrome materials).
- No dull areas (on polished surfaces).

Polished surfaces should measure no less than 50 when measured with a Gloss Meter, measuring at 60°.

If more than one slab is needed for the project, make sure they are identical in appearance.

Despite the strict procedures in place to ensure consistent appearance over time, slight variations in color and structure are possible due to the complex manufacturing system and the quartz used, which being a natural raw material, even if carefully selected from time to time can show slight variations in color and transparency.

The products that contain mirror, glass or mother of pearl may have small defects such as small holes or fractures due to the fragility of the raw materials used and therefore such defects must be considered characteristic of these products.

In addition to a visual inspection, verify compliance with the dimensional tolerances:

- Thickness tolerance ( $-1/16'' / +1/64''$ ).
- Flatness tolerance ( $5/32''$  in length /  $5/64''$  in width).

**NOTE:** The flatness must be measured at the center of the slab itself while in a horizontal position, taking into consideration the entire length and width of the slab (not the diagonals).

The back of the slab must have a smooth finish. Surface roughness must not exceed  $1/64''$ . Small cracks are allowed in the peripheral area up to 4'' from the edges.

The useable surface of the slabs is slightly less than the nominal surface and can vary from slab to slab. If you were to use the entire nominal surface you should carefully check the grey perimeter area shown in the drawing.

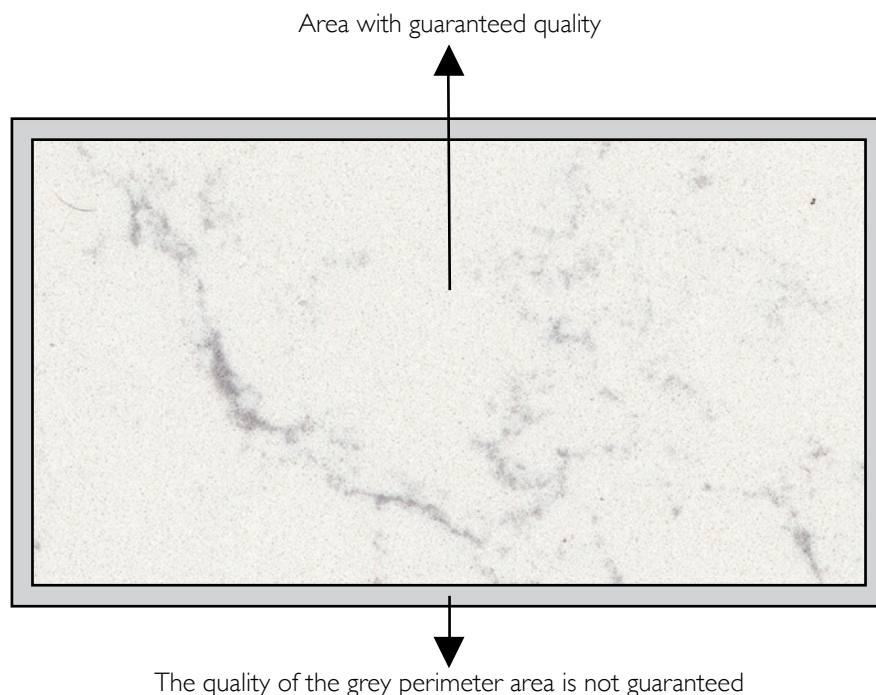

**NOTE :** If the fabricator believes the slab is unsuitable it must be replaced before starting work. Santa Margherita S.p.A. will not accept claims for slabs which have been cut or modified from their original condition.

# FABRICATION EQUIPMENT

## PERSONAL PROTECTIVE EQUIPMENT

- Safety gloves
- Safety goggles
- Dust mask type FFP3
- Steel toe safety shoes
- Hearing protection
- Work clothing

## FABRICATION TOOLS

The equipment required for fabrication is the classic type used for fabricating natural stone, with tools designed specifically for quartz. Below is a list of the equipment commonly used for fabricating SM QUARTZ:

- Bridge saw
- CNC contouring machine
- Waterjet cutter
- Edge polisher
- Diamond cutting blades
- Diamond grinding wheels
- Diamond burs
- Forklifts for handling
- A frames or pin racks to store slabs
- Overhead cranes
- Jib cranes
- Air compressor
- Clamps
- Dust extraction system
- Water treatment system
- Diamond polishing disks
- Work tables

14



### CUTTING THE SLAB

The information provided in this chapter is general and not specific. For detailed information on the type of tools and the speed rate of the blade (RPM), please contact the suppliers of the equipment or tools directly.

The SM QUARTZ slabs must be cut with bridge saws, CNC machines or waterjet equipment with tools specially designed for quartz.

Cutting is an important fabrication phase and is affected by several variables:

- The speed rate of the blade
- The revolutions per minute of the blade (RPM)
- The type of blade
- The wear conditions of the blade
- The conditions of the cutter surface
- The shape of the piece to be obtained
- The flow of cooling water
- The cutting surface temperature
- The conditions of the saw head

Each of these variables and their combination affect the result of the cut slab. Therefore when making a top, proper design and fabrication will prevent problems from occurring during production and after installation.



The travel speed of the blade and the rpm depends on several variables, such as the type of cutter; the type of blade, the metal binder and the grain of the diamond, the wear of the disk, etc. We therefore recommend to always consult the manufacturers or suppliers of tools and cutters for the correct setting of this data.

The table below shows indicative values commonly used for cutting:

<b>THICKNESS OF THE SLAB</b>	<b>NOTES</b>	<b>FEED SPEED</b>	<b>DIAMETER OF THE DISK</b>	<b>RPM</b>
1/2"	Full cut	78-3/4"/min	12" 14" 16" 20"	1850-1950 1600-1700 1400-1500 1100-1200
3/4"	Full cut or in steps of 3/16" - 3/8"	118"/min	12" 14" 16" 20"	1850-1950 1600-1700 1400-1500 1100-1200
1-1/4"	Full cut or in steps of 3/16" - 3/8"	118"/min	12" 14" 16" 20"	1850-1950 1600-1700 1400-1500 1100-1200

### GENERAL INSTRUCTIONS FOR CUTTING

- Ensure that the work surface is in good condition so that the slab is not able to move during cutting.
- Use blades and tools specifically designed for quartz.
- Check the wear condition of the tools and replace them if damaged or worn.
- Keep an abundant and constant flow of cooling water in the working area of the blade.
- First, make the cuts for the trimming on the two long sides of the slab.
- It is not recommended to plunge the blade into the slab to make the cut. If it is necessary however, sink the blade very slowly.
- The holes for the sink/cook top should be made after all other cutting operations are complete.
- If you do not have a water jet to make the holes for sinks/cook top cut outs and internal angles, then first drill at the corners and then make the cuts.
- Do not change the original surface finish of the slabs.
- Use the cutting parameters recommended by the manufacturers of the cutting tools.

18

**NOTE:** When fabricating dark materials, avoid the accumulation of water for a long period on the surface. This can cause marks which can no longer be removed. It is therefore recommended to dry the surface quickly.

## TIPS TO AVOID BREAKAGE

Certain measures can be taken to prevent cracks forming while fabricating the slabs.

- Trim the edges of the slab by 5/8" or more, starting from the longer sides.



1-Start from the longer sides



2-Then the shorter sides

- when cutting, if you note that the cut starts to close, before finishing it, insert a small wedge to keep it open.
- To cut the entire length of the slab, drill a hole ( $\varnothing$  1" / 1-1/4") near the end of the cut and cut advancing towards the hole.

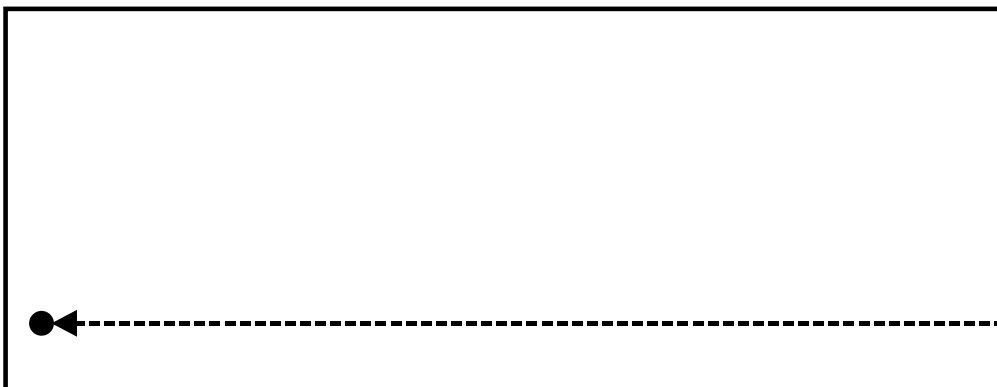

## FABRICATION TIPS

- If you need to make a cut by plunging the blade into the slab (plunge cut) drill a hole ( $\varnothing 1''/1-1/4''$ ) near the end of the cut and cut advancing towards the hole.

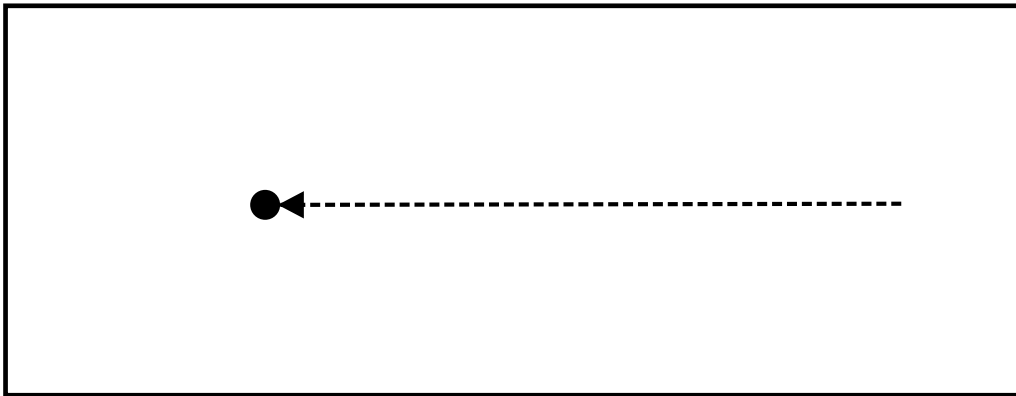

20

- If L-shaped pieces must be made (shape not recommended!), before cutting, drill the holes ( $\varnothing 1''/1-1/4''$ ), where the cut lines intersect, always making the shorter cut first.

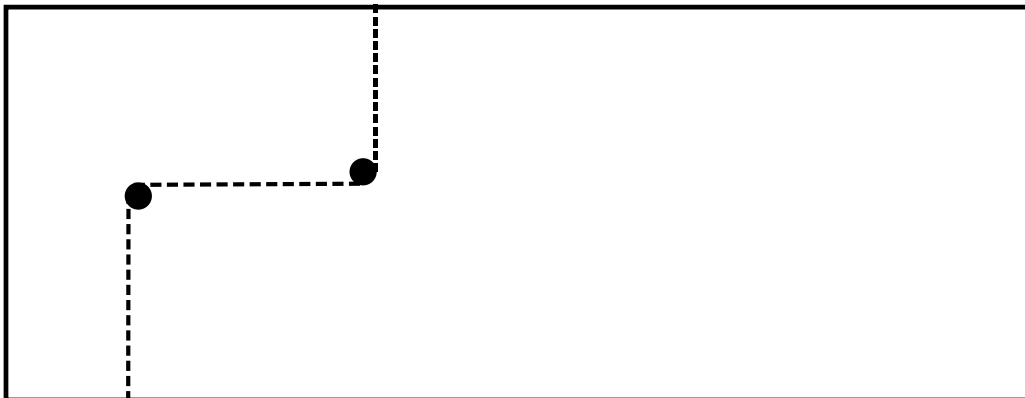

- To make U-shaped pieces, before cutting, make the holes ( $1\frac{1}{16}$ "- $1\frac{1}{4}$ " ) where the cut lines intersect, always making the shorter cut first.

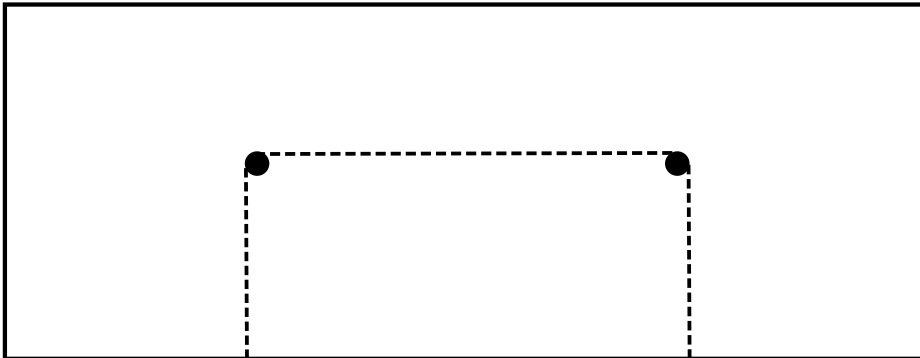

- All the inside corners should be rounded, with a minimum radius of  $\frac{4}{16}$ " for sink openings and  $\frac{3}{8}$ " in all other cases. By eliminating the corners, you remove the weak points most susceptible to breakage.

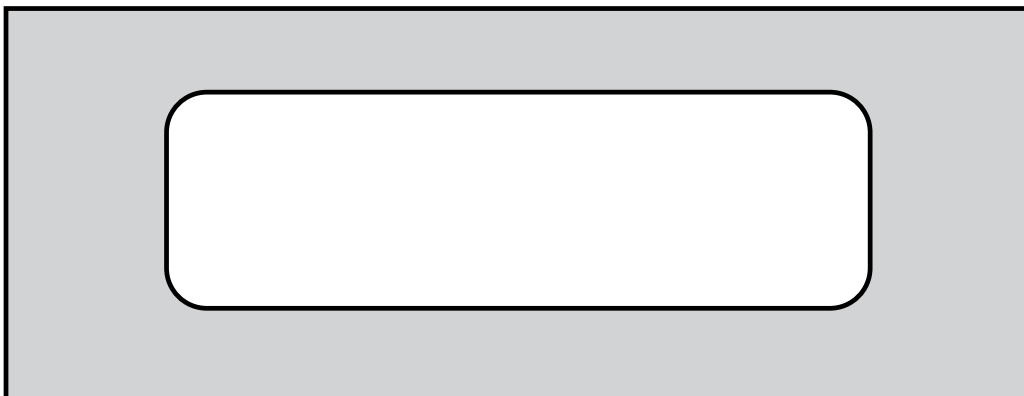

## FABRICATION TIPS

- On Vega, Victoria, Alberta and Zenith, you can make a cut along the longer side of the slab, at approximately 1-1/4"-2" from the edge and down about 20"-24". Then make the actual cut, parallel to the first cut and at about 1-1/4"-2" from this.

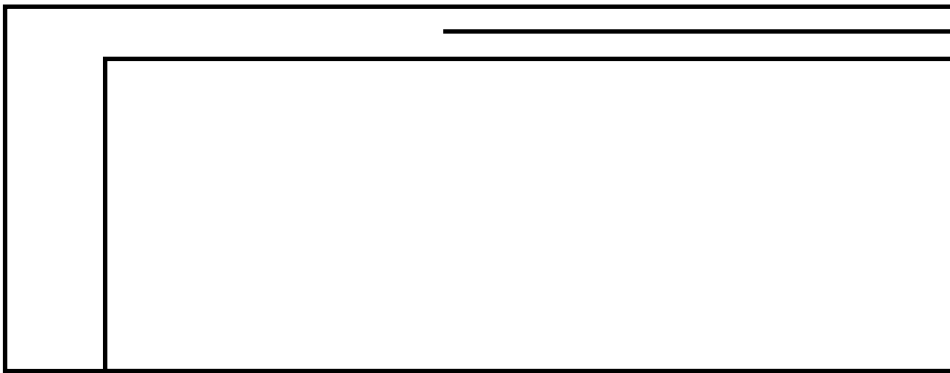

22

- If the opening for sinks or cooktop cut outs is made with a CNC machine and finger tool bits or with a Waterjet, the 4 corners should have a minimum radius of 4/16" (the largest possible). If the opening is made with a bridge saw, drill a hole ( $\varnothing$  1" / 1-1/4") at the four vertices, then make the cuts to join the holes in order to leave the edges rounded. This prevents breakages even after installation, therefore it should always be done.



1-Mark the vertices



2-Drill little holes corresponding to the vertices

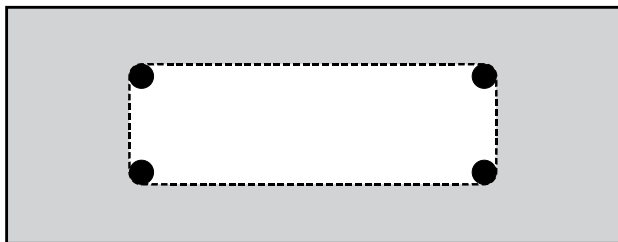

3- Make the cuts to join the holes

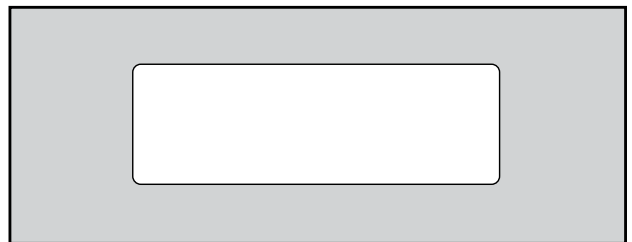

4-Hole with rounded edges

- The opening for installing cooktop cut outs must be sized for the cooktop to rest no more than 3/4" on the perimeter of the opening made. This is to avoid possible breakages caused by the section of the slab that is left below the cooktop.

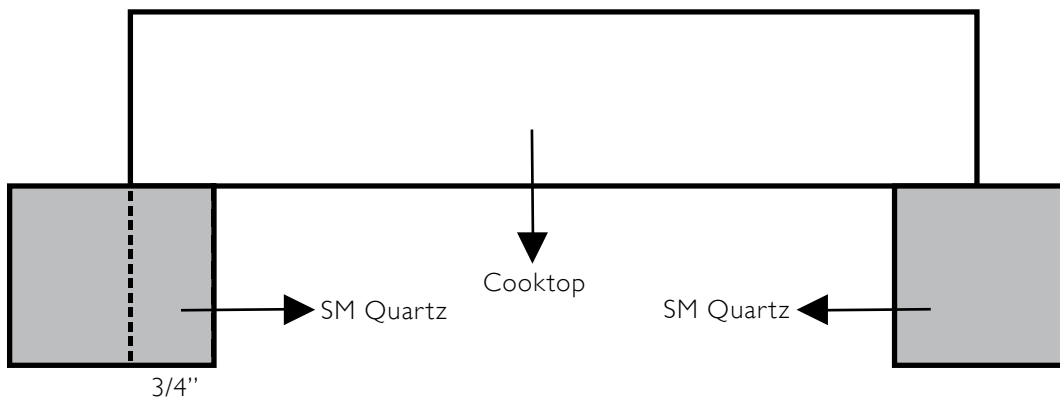

- Fabricating L-shaped surfaces from a single piece is not recommended especially when the length of the smaller side is more than 7-7/8". These shapes are subject to breaking during and after installation.

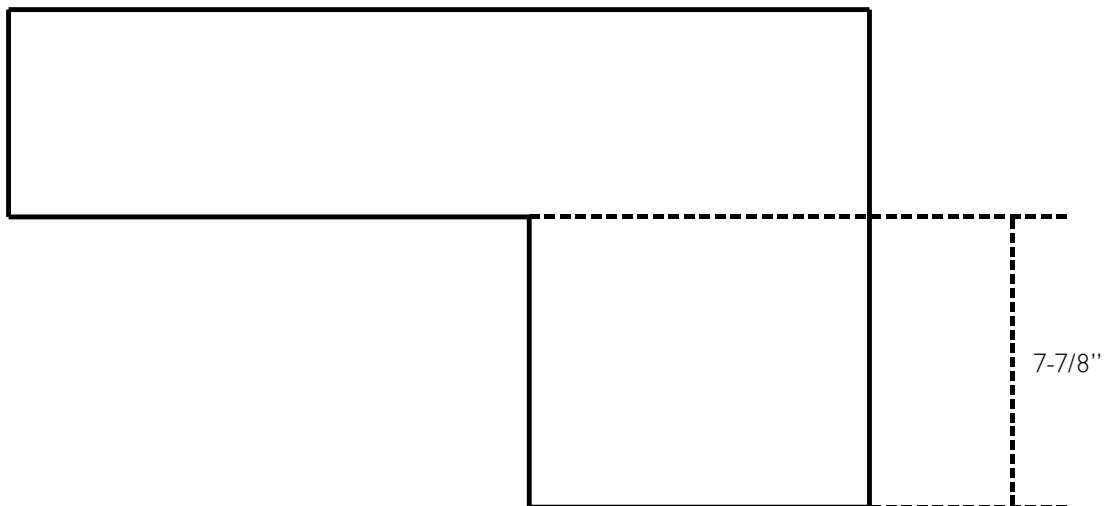

## FABRICATION TIPS

### GENERAL INSTRUCTIONS FOR CUTTING WITH CNC

- If cutting with CNC with a diamond blade, refer to chapter “General Instructions for cutting”.
- If cutting with a diamond cutter (finger bit), use cutters specifically for quartz. The finger bits compared to diamond blades remove a substantial amount of material during fabrication and therefore require a reduced feed rate, usually between 7-7/8"/min and 15-3/4"/min and 4000-8000 rpm.
- Fabrication must be carried out in compliance with the recommendations provided by the manufacturer of the CNC machines and tools used.
- Keep an abundant and constant flow of cooling water in the working area of the tool so as to prevent the cutter and the SM QUARTZ from overheating. It is appropriate to keep a greater amount of water in quartz fabrication in comparison with the flow usually used for fabricating marble or granite. The water flow must be directed into the working area of the cutter and in the same rotation direction of the tool.
- Periodically check the tool to verify its state of wear or damage. Make sure that the slab is secured to prevent movement during the fabrication process. If chipping or breakage occurs during fabrication, reduce the feed rate.



## GENERAL INSTRUCTIONS FOR CUTTING WITH WATERJET

Waterjet cutting is possible thanks to a water jet and abrasive particles at very high pressure (2500 - 5000 bar). The cut generated usually has a width ranging from 1/64" to 1/16". The feed rate affects the quality of the cut, which at high speeds becomes very irregular and serrated on the bottom.

Poor quality cuts can cause the SM QUARTZ slab to break.

The quality and speed of the cut can be affected by many variables, such as the type of equipment used, the pressures used, the type and amount of abrasive, the equipment software etc.

For this reason, it is essential to consult the equipment supplier for information on operational procedures.

Some generic measures for fabricating are:

- Reduce the feed rate to improve the quality of the cut
- Use abrasives specifically made for use with quartz
- Inspect the equipment regularly
- Use updated software
- When possible, the direction of the cut must be from the outside to the inside
- The cut must begin as far as possible from the piece to be obtained
- Make sure the support surface is in good condition
- Make sure the correct quantity of abrasive is used
- If necessary, reduce the distance between the nozzle and the slab.

## FABRICATION TIPS

### POLISHING EDGES

The edges can be polished with edge polishing machines for stone materials using grinding wheels with a diameter of 5-1/8" specifically for quartz. The piece to be polished must be secured to prevent any movement during polishing. The cooling water must have a steady and adequate flow to ensure sufficient cooling. The feed rate and the pressure of the grinding wheels must be adjusted in order to obtain a good polishing, and may vary depending on the type of machine and abrasives used.

Indicative grinding wheel series to be used for polished finish: 100 200 400 500-800 1500-2000 2000-3000

**NOTE:** When machining dark materials, avoid the accumulation of water for a long period on the surface. This could cause marks which can no longer be removed. It is therefore recommended to dry the surface quickly.

## POSITIONING JOINTS AND GLUING

When planning the joint location on tops made of several pieces, in addition to allowing the maximum use of the slab surface, you must consider certain technical aspects:

- The joints must be at least 5-7/8" from the holes (sink or cooktop cut out).

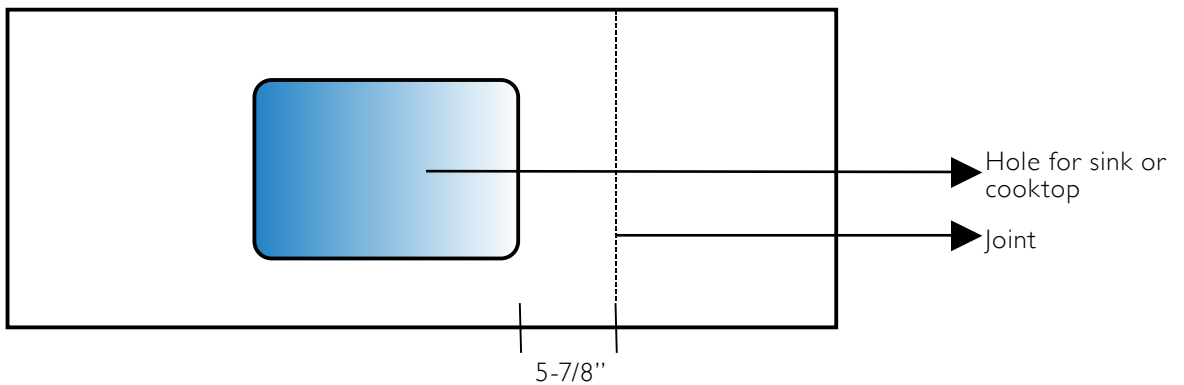

- The joint must not be positioned above the dishwasher or any other household appliance that radiates heat.

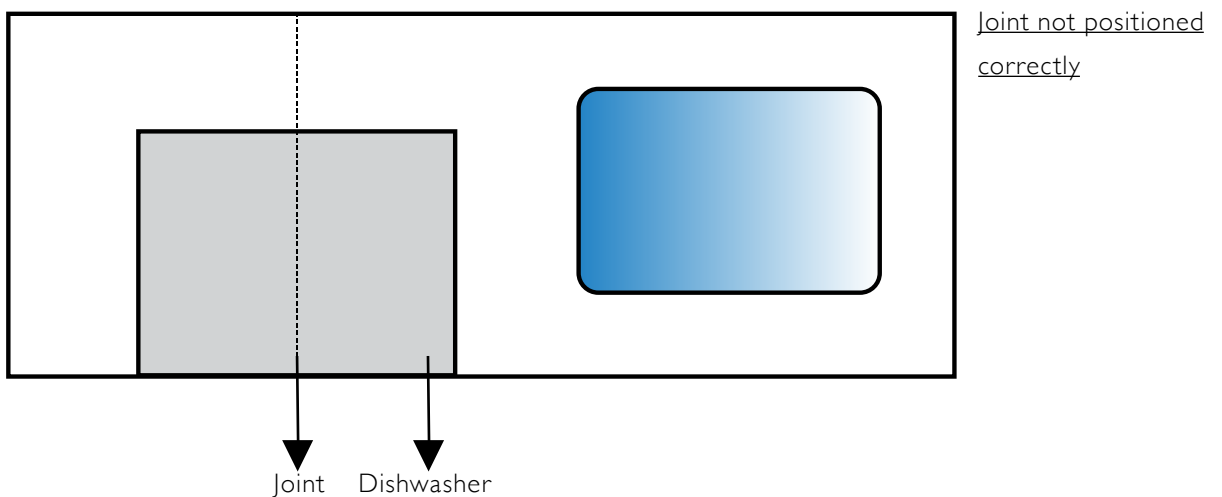

## FABRICATION TIPS

- It is not recommended to position the joint in line with the cooktop.

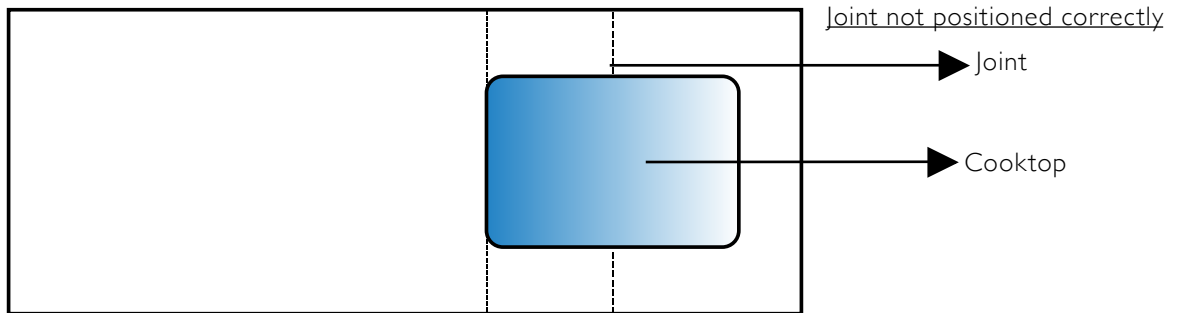

- The joint must not affect any overhangs.

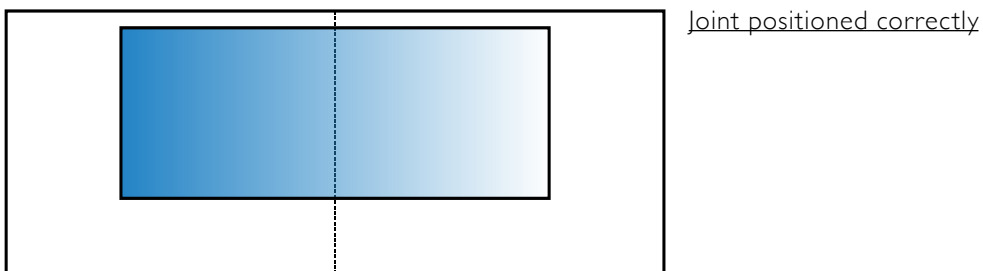
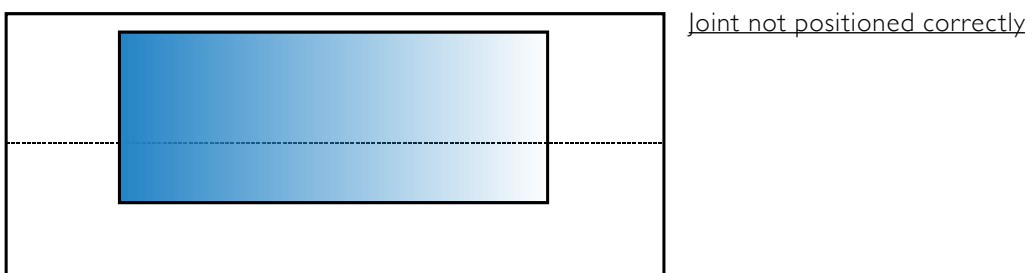
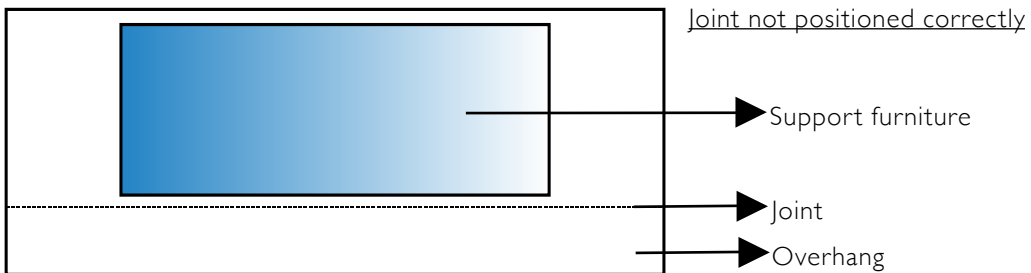

- If the top is made from two or more pieces, it is not necessary to connect the corners that are created in the joint areas.

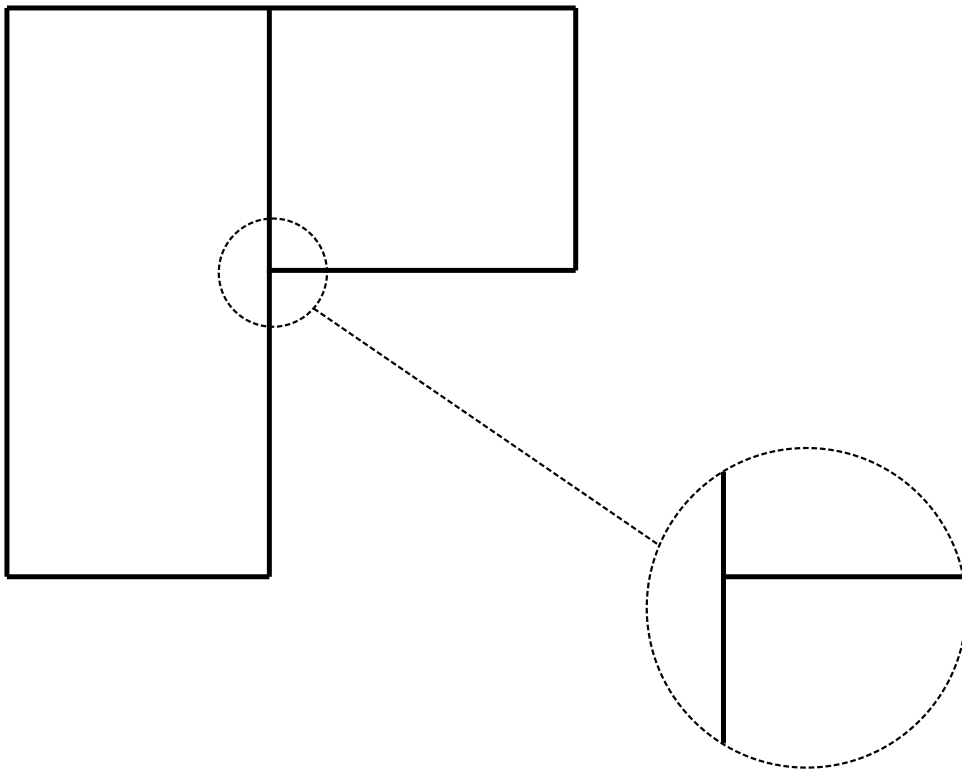

- The joint area must be well supported from below.
- Carefully check the alignment of the two parts before gluing.

## FABRICATION TIPS

- Use masking tape to protect the edges of the two parts to be glued.
- Use alcohol or acetone to clean the parts to be glued.
- The surfaces to be glued must be rough, flat, dry and thoroughly clean.
- For gluing you can use polyester resin or acrylic epoxies, following the instructions provided by the manufacturer.
- If you need to adjust the color of the polyester based adhesive, use specific colored pigment.
- It is recommended to remove excess mastic from the top before it hardens completely.
- The joint must be as thin as possible (max 1/16"), therefore we recommend the use of proper equipment for the purpose (such as Gorilla Grip system).

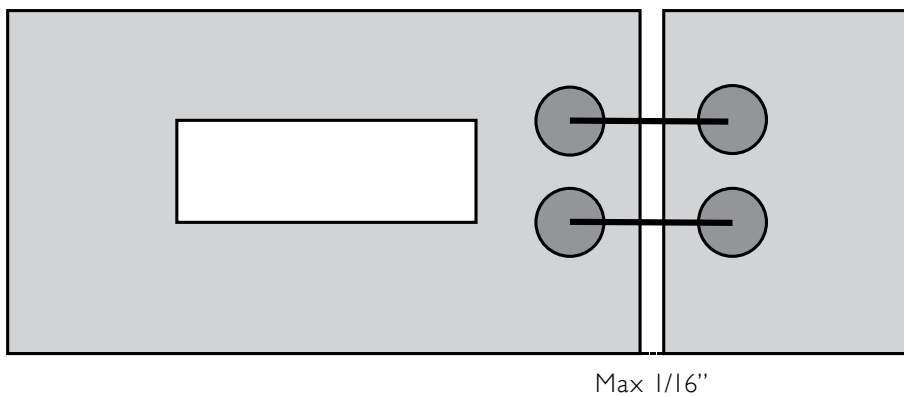

- Leave the retaining clips in place until the glue has set, then remove the clips and the masking tape and remove any excess adhesive with alcohol or acetone.
- Avoid joining the two parts mechanically with screws or nails in direct contact with SM QUARTZ.

Specific mastics for gluing many products of the SM QUARTZ range can be found at [www.tenax4you.com](http://www.tenax4you.com) and [www.integra-adhesives.com](http://www.integra-adhesives.com).

# COUNTER INSTALLATION

## INSTALLATION INSTRUCTIONS

Tops must be handled in a vertical position, avoiding twists or impacts. Before proceeding with the installation, carefully check that the counter is not scratched, has no cracks or aesthetic imperfections.

Make sure the support surface of the unit is perfectly level, and if composed of several parts, that these are levelled, adjusting the legs of the unit, if necessary. Gently rest the counter upright on the rear side of the unit, apply some neutral silicone on a few points on the base of the unit and then lower the top by adjusting its position.

in order to keep the counter clean while adhering the back, or joining L-shaped counters, apply masking tape near the areas to be joined and then apply a bead of neutral silicone.

Remove excess silicone with a spatula, razor or putty knife. The masking tape should be removed only after the silicone has hardened. Remove any silicone residue with sharp metal scrapers, taking care not to mark the surface.

To secure the counter to the unit, only use neutral silicone and not epoxy adhesives or other adhesives. In fact, the silicone guarantees the necessary flexibility to compensate for small movements caused by thermal contraction and expansion.

Leave an expansion space of about 1/8" between the counter and the walls or the units and seal it with neutral silicone, always making sure to first protect the surface with masking tape.

Do not apply pressure to the quartz around any sink or cooktop cut outs.

# COUNTER INSTALLATION

## OVERHANGS

- Overhangs must never be greater than  $\frac{1}{3}$  of the length, and the remaining  $\frac{2}{3}$  of the counter must be well supported.

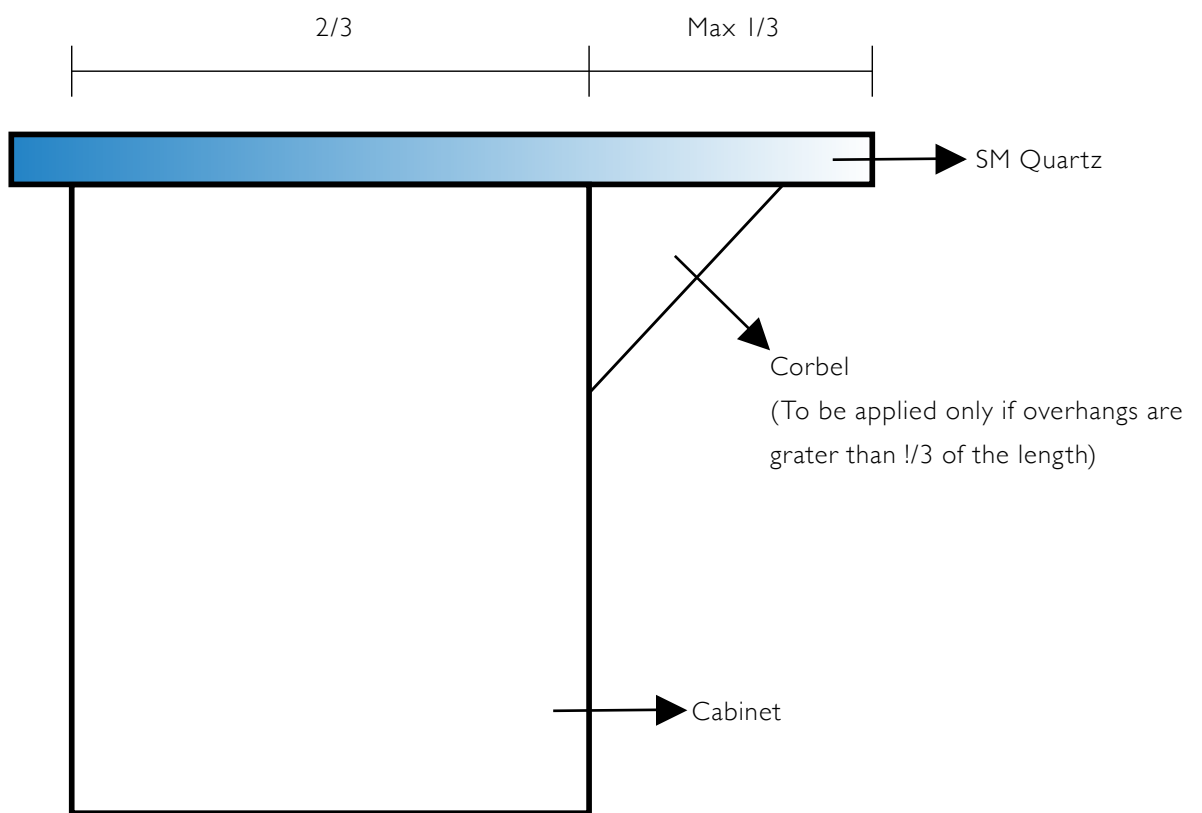

32

- It is allowed to have an unsupported overhang of 10" for tops that are  $\frac{3}{4}$ " thick and of 13- $\frac{3}{4}$ " for 1- $\frac{1}{4}$ " tops.
- If the overhang exceeds the requirements, it must be supported with brackets, legs or columns.



## POST INSTALLATION TROUBLESHOOTING

Many problems can occur around the cooktop area due to:

- Excessive heating of the top which causes breakage due to thermal shock or repeated cycles of extreme heat/cold.
- Major weaknesses in the area of the hole, typically in the corners, especially if they are not rounded.
- Incorrect cooktop hole size (the cooktop should not exceed 3/4" over the perimeter of the cut out).
- To reduce the heat transfer from the cooktop, glue specific adhesive tape for the thermal insulation of household appliances on the edge of the hole (1452 Aluminium Tape of 3 M) This tape should never be removed.

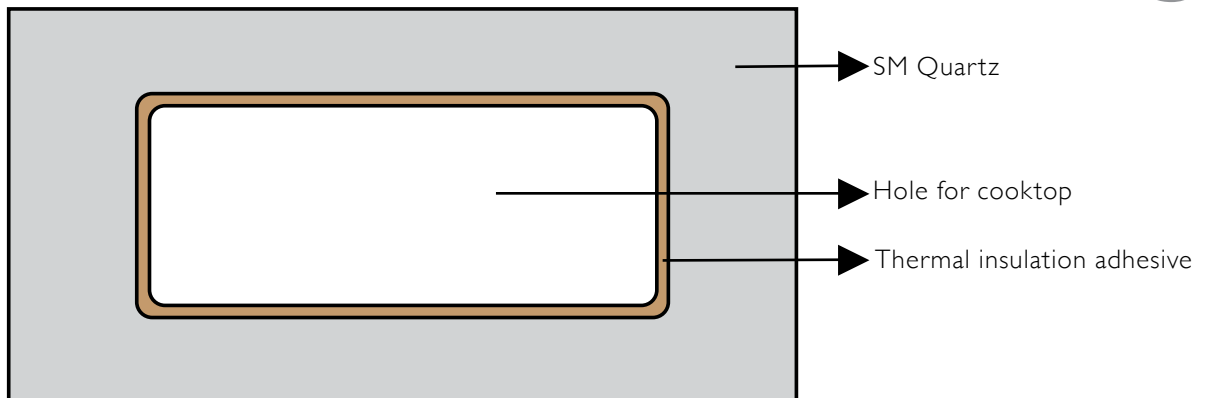

- If there is a dishwasher, washing machine, oven or any appliance that produces heat below the counter, use silicone to glue an insulating panel (in polyurethane or heat-reflective) under the counter where these appliances are positioned..

## CARE AND MAINTENANCE

### CLEANING AFTER FABRICATION

When slab machining is complete, remove any residue from the counter with running water and a clean cloth. Thoroughly dry the counter.

Thoroughly clean the counter by spraying an acidic or slightly alkaline pH detergent, specific for quartz, on the surface, distributing it evenly with a soft sponge. Leave it for 5 minutes and then rinse with water until all the detergent is removed. Remove any excess water with a cloth and dry.

If, after cleaning, a haze remains on the surface, rinse again. If there are traces of dirt, clean again.

The materials containing mother of pearl should not be washed with acidic cleaners.

Acidic products ruin the surface of the mother of pearl.

On smooth surface tops, we do not recommend the application of a surface treatment, such as protective or sealant wax, which over time may cause loss of shine or unevenness in the surface, if not applied correctly

## 34

### CLEANING AFTER INSTALLATION

On completion of installation, thoroughly clean the surface by spraying an acidic or slightly alkaline pH detergent, specific for quartz-resin agglomerates, on the surface, distributing it evenly with a soft sponge. Leave it for 5 minutes and then rinse with water until the detergent is completely removed. Remove any excess water with a cloth and dry.

The materials containing mother of pearl should not be washed with acidic cleaners.

Acidic products ruin the surface of the mother of pearl.

**NOTE: Pay attention to delicate metal parts and other acid-sensitive materials**

## CLEANING AND ROUTINE MAINTENANCE

For routine cleaning of SM QUARTZ surfaces use a damp cloth or a paper towel and, if necessary, a small amount of neutral pH or slightly acidic detergent, specific for daily cleaning of quartz.

Apply the product directly on the surface leaving it for a few seconds, then rinse with a sponge and water, then dry thoroughly.

The materials containing mother of pearl should not be washed with acidic cleaners.

Acidic products ruin the surface of the mother of pearl.

Pay attention to delicate metal parts and other acid-sensitive materials.

## CLEANING STUBBORN STAINS

Counters made with SM QUARTZ provide great stain resistance to many everyday products.

However, the removal of some types of stains can require special cleaning, particularly if they are not removed quickly from the counter surface.

In this case, thoroughly clean the surface by applying a neutral pH or slightly alkaline detergent, specific for cleaning quartz, distributing it evenly with a soft sponge (such as a white non abrasive 3M Scotch-Brite®). Leave it for 5 minutes and then rinse with water until the detergent is completely removed.

Remove any excess water with a clean dry cloth.

If the stain is not removed completely, repeat the process or use Magic Eraser®.

The materials containing mother of pearl should not be washed with acidic cleaners.

Acidic products ruin the surface of the mother of pearl.

Pay attention to delicate metal parts and other acid-sensitive materials.

35

## PREVENTING DAMAGE FROM THERMAL SHOCK AND IMPACT

The SM QUARTZ surface is heat resistant and can resist limited exposure to the normal cooking temperatures of pots, pans and plates without being damaged. We strongly recommend the use of hot pads and/or trivets to prevent thermal shock.

## CARE AND MAINTENANCE

### RECOMMENDED PRODUCTS FOR CLEANING

- Plus 10
- Quick Clean
- 409 cleaner for stone
- Zep marble granite & quartz cleaner
- Simple green stone cleaner

**NOTE:** The products must be used at the dilution suggested by the manufacturer.



# TECHNICAL FEATURES

## TECHNICAL SPECIFICATIONS

CHARACTERISTICS	STANDARD	VALUE	NOTES
Apparent density	EN 14617-1	2000 - 2500 Kg/m <sup>3</sup>	
Water absorption	EN 14617-1	≤ 0,10 %	
Bending resistance	EN 14617-2	28 - 100 MPa	
Abrasion resistance	EN 14617-4	25 - 33 mm	
Frost resistance	EN 14617-5	KMf25 0,9 - 1,2	
Thermal shock resistance	EN 14617-6	$\Delta m\% \leq 0,07\%$ $\Delta R\% \leq 25\%$	Test temperature: 70°C
Impact resistance	EN 14617-9	1,0 - 5,5 J ≥ 2,0 J	For 10-12 mm thickness For 20-30 mm thickness
Chemical resistance	EN 14617-10	C4	
Thermal expansion coeff.	EN 14617-11	$21 - 50 \times 10^{-6} \text{ }^\circ\text{C}^{-1}$	
Dimensional stability	EN 14617-12	Classe A (<0,3 mm)	
Electrical resistivity	EN 14617-13	$R_s \geq 1010 \text{ } \Omega$ $R_v \geq 108 \text{ } \Omega \text{ m}$	With reference to the surface With reference to the volume
Compression resistance	EN 14617-15	150 - 250 MPa	
Mohs hardness	EN 101	max 7 Mohs	
Thermal conductivity	EN 12524	1,3 W/(m K)	From tabulated values
Reaction to fire	EN 13501-1	A2fl-s1	Bfl-s1 for Vega, Victoria, Alberta

38

## STAIN RESISTANCE

The stain resistance characteristics of the product were determined according to the UNI EN 12720 standard on materials with an untreated glossy finish.

The stain resistance was evaluated after 2 and 16 hours of application of the product, after cleaning the material with Top Cleaner Faber.

<b>STAINING AGENT</b>	<b>2 HOURS</b>	<b>16 HOURS</b>
Scented ace thick bleach	Halo or mark	Halo or mark
Wine vinegar Cirio	No visible effect	No visible effect
Acetone	Halo or mark	Halo or mark
Bio presto (hand wash)	No visible effect	No visible effect
Birra Frost Premium	No visible effect	No visible effect
Coffee applied hot	No visible effect	No visible effect
Cif cream particles	Slight halo	Halo or mark
Sodium chloride solution at 10%	Slight halo	Halo or mark
Coca Cola	No visible effect	No visible effect
Deteralcool Noi Voi	Slight halo	Slight halo
Dixan washig-up gel with vinegar	No visible effect	No visible effect
Finish Power Gel	Halo or mark	Halo or mark
Fornet	Slight halo	Slight halo
Milk	No visible effect	No visible effect
Lysoform WC Gel all in one	No visible effect	No visible effect
Mastro Lindo	Slight halo	Slight halo
Olive oil	No visible effect	No visible effect
Black permanent marker	Halo or mark	Halo or mark
Sai perfumed ammonia	Slight halo	Slight halo
Smac Brilla Acciaio	No visible effect	No visible effect
Spic & Span Marsiglia	No visible effect	No visible effect
Concentrated lemon juice	No visible effect	No visible effect
Svelto Brillantante (dishwasher liquid)	No visible effect	No visible effect
Svelto Piatti Gel Attivo (washing-up liquid)	No visible effect	No visible effect
Tea applied hot	No visible effect	No visible effect
Tomato Ketchup Calvè	No visible effect	No visible effect
Viakal Multiazione (multi-action spray)	No visible effect	No visible effect
Red wine	No visible effect	No visible effect

39

NOTE: Tests non valid on products containing mother of pearl.

40

**ATTENTION!**

These instructions are based on our experience. Even if we strive to ensure that the information provided is precise and complete, Santa Margherita SpA does not provide a warranty or cannot be held responsible for its exactness and applicability.





SANTAMARGHERITA S.P.A.  
Via del Marmo, 1098  
37020 Volargne (VR) - Italy  
Tel. +39 045 6835888  
Fax +39 045 6835800  
info@santamargherita.net

SANTAMARGHERITA USA  
phone: +1 800 3976654  
usa@santamargherita.net

SANTAMARGHERITA HONG  
KONG  
phone: +852 2804 1280  
hk@santamargherita.net

DOWNLOAD NOW  
THE NEW IPHONE/IPAD APP  
 Available on the  
**App Store**  
**“SM surface”**  
santamargherita.net

[www.santamargherita.net](http://www.santamargherita.net)

**santamargherita**